



**Manufactured in
Canada**

OMNICHECK 360° VISION SYSTEM

Inspects fill level, cap defects, label defects and barcode up to 1,600 containers per min

OMNICHECK 360°

VISION SYSTEM

System Highlights

- 100% Automatic Product Inspection
- Multiple High-Resolution Camera configurations
- Capping and Crimping Defects
- Cap and Crimp Color
- Label Inspection
- Fill Level Inspection
- Foam Inspection
- Foreign Crown Inspection
- Barcode Inspection
- High Resolution Encoder Tracking
- 22" HMI with Remote Access
- IP65 Electronics Enclosure

Specifications

Electrical Requirements

115 VAC 50-60 Hz, 10A
230 VAC 50-60 Hz, 5A

Operating Temp.

0°C to 45°C

Operating Speed

Up to 1600 CPM

Rejector

Omniline Low Pressure
Impulse Rejector

Display Languages

English, French, Spanish

Environmental Standards

Nema 4X / IP65

Materials

Stainless Steel
Construction

Dimension

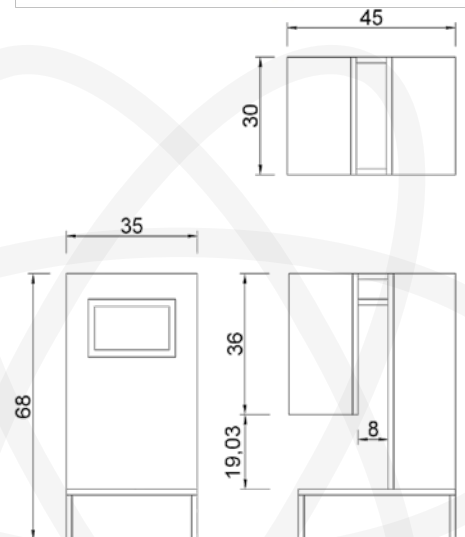
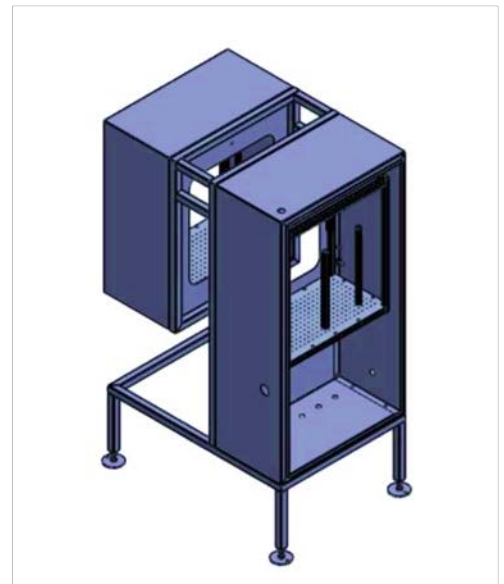

Contact Details

 Omnifission Inc.
1900 Clark Blvd, Unit 1 & 2
Brampton, ON L6T OE9

 905-405-9777

 www.omnifission.com  orders@omnifission.com